



COMPONENTS

- Material: Food approved high density polyethylene
- Standard Color: White (Other colors on request)
- Plastic Handle With Finger Grip
- Pour Spouts available
- Gasket: EPDM (Ethylene Propylene Diene Monomer)

WALL THICKNESS

	cm	inch
• Pail	.152	.060
• Gasket Lid (654)	.183	.072
• Snap On Lid (624)	.155	.061
• Snap On TT Lid (623)	.155	.061

STANDARD WEIGHT (+/- 2%)

	g	lb.
• Pail (including handle)	445	0.98
• Gasket Lid (including gasket) (654)	195	0.43
• Snap On Lid (624)	129	0.28
• Snap On TT Lid (623)	146	0.32

THERMAL RESISTANCE (Tested with water)

- Filling from -38°C (-36°F) to 82°C (180°F)
- Warehousing from -40°C (-40°F) to 39°C (102°F)

TOP LOADING RESISTANCE

	kg	lb.
• With Gasket Lid (654)	180	396
• With Snap On Lid (624)	112	246
• With Snap On TT Lid (623)	112	246

CAPACITIES

VOLUME	LITRES	GALLONS	
		IMP.	U.S.
Nominal	11.00	2.42	2.91
Maximum to Overflow	12.19	2.68	3.22
Maximum with Gasket Lid	11.44	2.52	3.02
Maximum with Snap On Lid	11.54	2.54	3.05
Maximum with Snap On TT Lid	11.59	2.55	3.06

Product Density g/cc	Maximum Weight Filled with Lid					
	GASKET LID		SNAP ON 624		SNAP ON TT 623	
	kg	lb	kg	lb	kg	lb
0.5	6.04	13.29	6.06	13.33	6.09	13.40
0.6	7.25	15.95	7.27	15.99	7.31	16.08
0.7	8.46	18.61	8.48	18.66	8.53	18.76
0.8	9.67	21.27	9.69	21.33	9.75	21.44
0.9	10.87	23.92	10.91	23.99	10.97	24.12
1.0	12.08	26.58	12.12	26.66	12.18	26.80
1.1	13.29	29.24	13.33	29.32	13.40	29.49
1.2	14.50	31.90	14.54	31.99	14.62	32.17
1.3	15.71	34.56	15.75	34.65	15.84	34.85
1.4	16.92	37.22	16.96	37.32	17.06	37.53
1.5	18.12	39.87	18.18	39.99	18.28	40.21

Above is a guideline only.
Customer should verify with specific product to be packaged.

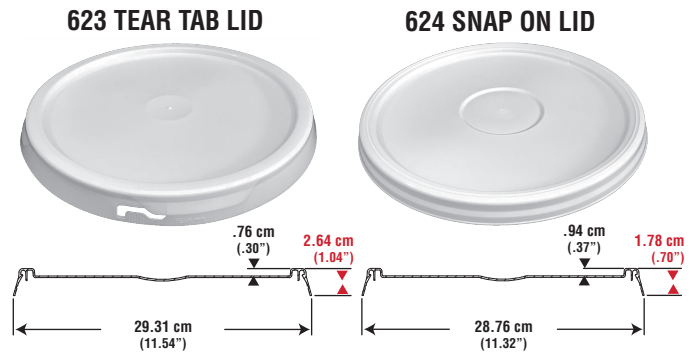

2.5 IMPERIAL GALLON PAIL

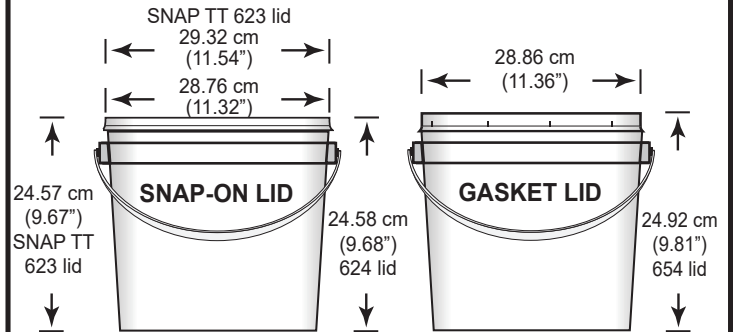

NESTING

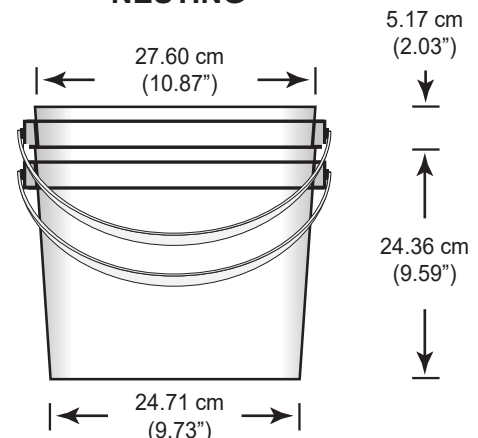

PALLET UTILIZATION

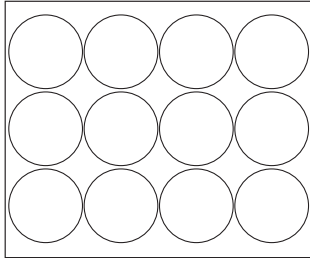

122 cm x 102 cm
(48" x 40")

IMPORTANT: Never let pails overlap edge of pallet

RECOMMENDED STACKING HEIGHT

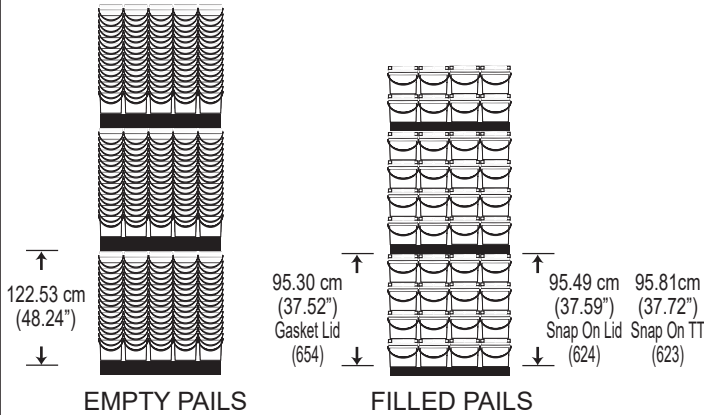

SHIPPING DATA

Quantity	723 PAIL		SNAP-ON (624)		SNAP-ON TT (623)		GASKET (654)	
	300/plt	100/box	600/plt	90/box	600/plt	50/box	300/plt	
Dimensions*	49.25" x 41.25" x 48.50"	25.75" x 13.00" x 22.50"	46.00" x 41.50" x 18.00"	25.75" x 13.00" x 22.50"	50.50" x 42.50" x 19.50"	25.75" x 13.00" x 20.25"	46.00" x 41.50" x 14.75"	
Volume	57.02 cu. ft.	4.36 cu. ft.	19.89 cu. ft.	4.36 cu. ft.	24.22 cu. ft.	3.92 cu. ft.	16.29 cu. ft.	
Weight**	135.50 kg / 298.10 lbs	13.90 kg / 30.58 lbs	78.90 kg / 173.58 lbs	14.14 kg / 31.11 lbs	89.60 kg / 197.12 lbs	10.60 kg / 23.32 lbs	60.00 kg / 132.00 lbs	

* AND ** DOES NOT INCLUDE WOODEN PALLET

NOTE: pallets are wrapped up in a protective stretch film.

OPENING

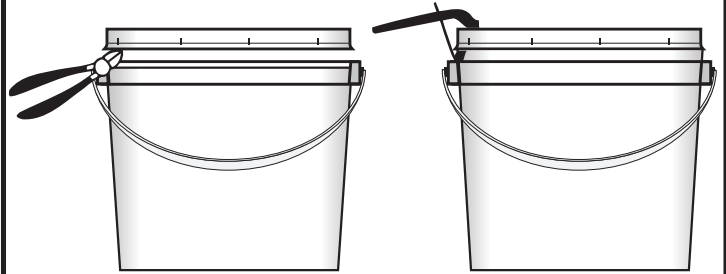

Cutters

Lid Lifter

CLOSING

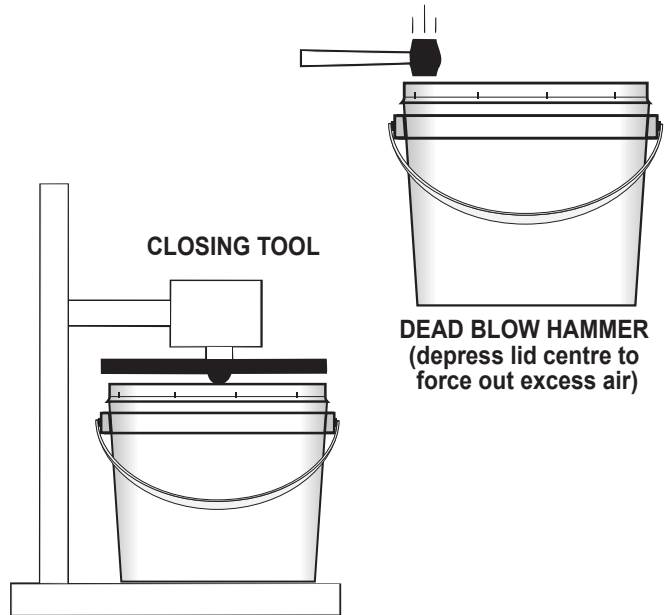

PRINTING

DRY OFFSET PRINTING (UP TO MAXIMUM 4 PANTONE COLORS)

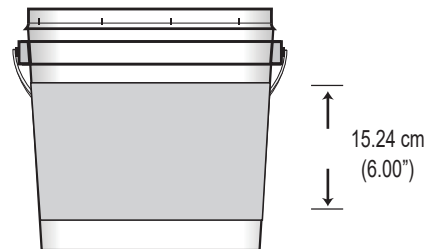

APPROVALS

Pro-Western Plastics Ltd. disclaims any liability for the use of the information and data contained herein. We reserve the right to alter or modify any product and/or specification, at any time.