



COMPONENTS

- Material: Food approved high density polyethylene
- Standard Color: White (Other colors on request)
- Plastic Handle
- Gasket: EPDM (Ethylene Propylene Diene Monomer)

WALL THICKNESS	cm	inch
• Pail	.157	.062
• Gasket Lid (618)	.155	.061

STANDARD WEIGHT (+/- 2%)	g	lb.
• Pail (including handle)	348	0.77
• Gasket Lid 618 (including gasket)	126	0.28
• Gasket Lid 618 (no gasket)	112	0.25

THERMAL RESISTANCE (Tested with water)

• Filling	from 38°C (-36°F) to 82°C (180°F)
• Warehousing	from -40°C (-40°F) to 39°C (102°F)

TOP LOADING RESISTANCE	kg	lb.
• Lid (No gasket)	180	396
• Lid (With gasket)	180	396

CAPACITIES

VOLUME	Litres	GALLONS	
		Imp.	U.S.
Nominal	7.57	1.67	2.00
Maximum to Overflow	8.90	1.96	2.35
Maximum with Lid (with Gasket)	8.60	1.89	2.27
Maximum with Lid (no Gasket)	8.30	1.83	2.19

PRODUCT DENSITY g/cm ³	Maximum Weight Filled with Lid			
	NO GASKET		WITH GASKET	
	kg	lb	kg	lb
0.5	4.54	9.98	4.38	9.64
0.6	5.44	11.98	5.26	11.56
0.7	6.35	13.97	6.13	13.49
0.8	7.26	15.97	7.01	15.42
0.9	8.17	17.97	7.88	17.34
1.0	9.07	19.96	8.76	19.27
1.1	9.98	21.96	9.64	21.20
1.2	10.89	23.96	10.51	23.13
1.3	11.80	25.95	11.39	25.05
1.4	12.70	27.95	12.26	26.98
1.5	13.61	29.94	13.14	28.91

Above is a guideline only.
Customer should verify with specific product to be packaged.

618 GASKET LID

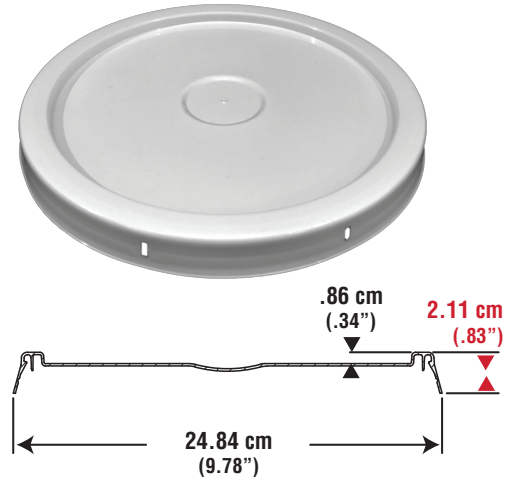

2 U.S. GALLON INDUSTRIAL CONTAINER

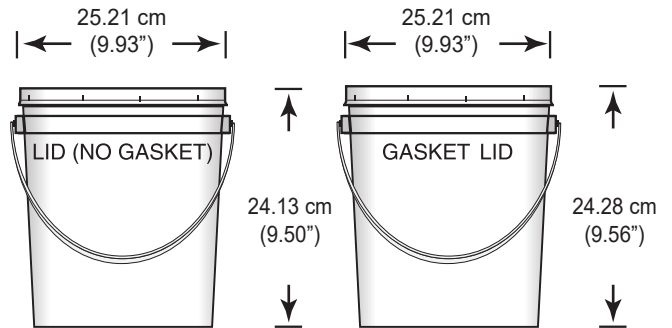

NESTING

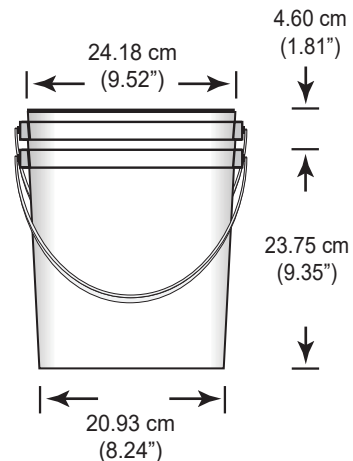

PALLET UTILIZATION

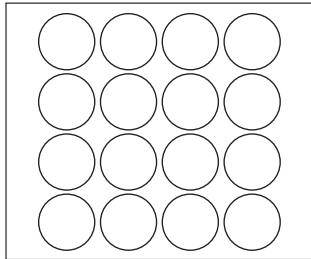

**122 cm x 102 cm
(48" x 40")**

IMPORTANT: Never let pails overlap edge of pallet

RECOMMENDED STACKING HEIGHT

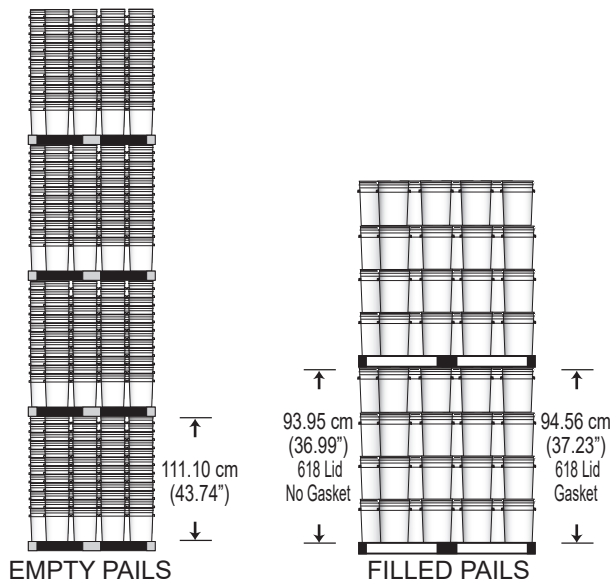

OPENING

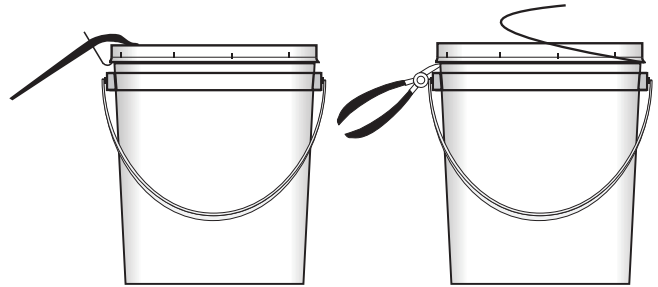

CLOSING

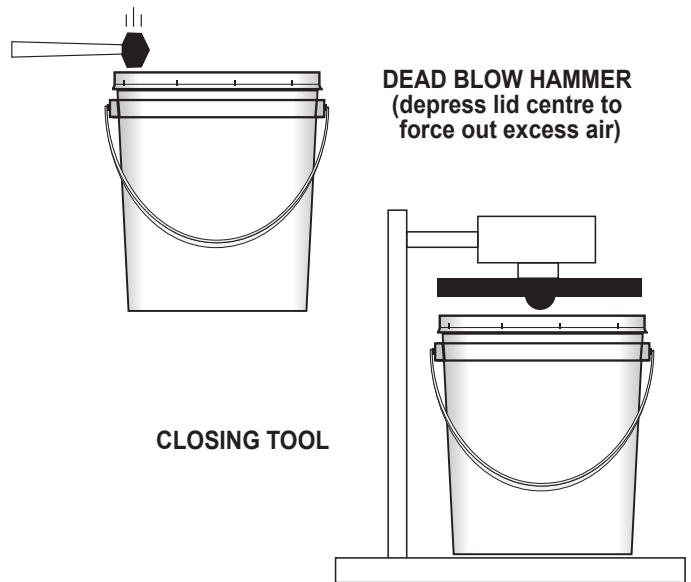

PRINTING

DRY OFFSET PRINTING (UP TO MAXIMUM 4 PANTONE COLORS)

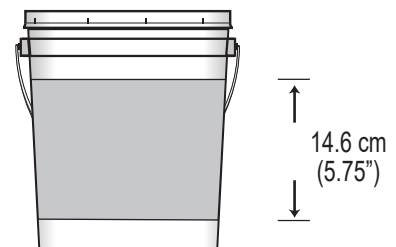

SHIPPING DATA

	718 PAIL	618 LID (No Gasket)	618 LID (With Gasket)
Quantity	400/pallet	100/box	100/box
Dimensions*	49.50" x 41.50" x 44.00"	20.25" x 10.25" x 29.00"	20.25" x 10.25" x 29.00"
Volume	52.31 cu. ft.	3.48 cu. ft.	3.48 cu. ft.
Weight**	141.00 kg 310.20 lbs	12.05 kg 26.51 lbs	13.45 kg 29.59 lbs

* AND ** DOES NOT INCLUDE WOODEN PALLET

APPROVALS

Pro-Western Plastics Ltd. disclaims any liability for the use of the information and data contained herein. We reserve the right to alter or modify any product and/or specification, at any time.